



HİDROLİK GÜCÜN ADI | THE NAME OF HYDRAULIC POWER



HİDROLİKSAN®
HALİM USTA

HİDROLİK PRES İML. SAN. TİC. LTD. ŞTİ.





HİDROLİKSAN®
HALİM USTA
HİDROLİK PRES İML. SAN. TİC. LTD. ŞTİ.



TÜRKİYE'DEN DÜNYA'YA

FROM TURKEY TO WORLD



HİDROLİK GÜCÜN ADI

THE NAME OF HYDRAULIC POWER



Halim USTA
Genel Müdür/General Manager

Hakkımızda



1982 yılında üretime başlayan Hidroliksan Halim Usta firması, 10.000 metre karelik modern tesisinde 3000 ton kapasiteye kadar pres imalatını sürdürmektedir.

Hidroliksan makineleri, otomotiv, tarım, metal şekillendirme ve geri dönüşüm sektörleri başta olmak üzere, güç ve biçimlendirme ihtiyacı olan her sektöre hitap etmekte ve bu sektörlerin ihtiyacına cevap verebilmenin gururunu yaşamaktadır.

Güçlü yapısı, sahip olduğu kaliteli yönetim sistemi, eğitilmiş insan kaynakları ve takipçisi olduğu teknoloji ile sanayicisi için yüksek kaliteli çözümler üreten Hidroliksan, kalite ve hizmet anlamında tüm dünyanın güvenini kazanmıştır.

Dünyadaki teknolojik gelişmeleri yakından takip eden Hidroliksan, bu gelişmeleri ürünlerine uygulayarak, müşterilerine üstün kalite, zamanında teslim, uygun fiyat ve özverili bir satış sonrası destek sunmaktadır.

Başta Avrupa, Orta Doğu, Batı Afrika ve Asya ülkeleri olmak üzere, 40'ın üzerinde ülkeye ihracat yapan firmamız, bu ülkelerin hemen hepsinde bayilere sahip olmakla beraber fuar ve diğer tanıtım faaliyetlerinde bulunmaktadır. Tanıtım faaliyetlerine büyük önem veren Hidroliksan, yılda 20 den fazla fuara bayileri ile beraber ve direk olarak katılmaktadır.

Üretimimizde bulunan ve yeni yeni teknolojik gelişmeleri takip ederek üretilen ürünlerimizin başında ;

- 1000 Ton kapasiteye kadar Atölye presleri
- 3000 Ton kapasiteye kadar sıvama presler
- 3000 Tona kadar ütüleme presleri
- 1000 ton kapasiteye kadar kolonlu presler
- 500 Ton kapasiteye kadar c tipi presler

Bulunmaktadır. Bunların yanında, küçük atölyelere hitap eden hortum sıkma presleri, bronz presleri, büyük presleri ve daha bir çok hidrolik aksam da üretim yelpazemizde yer almaktadır.

Değişen ve gelişen yüzü ile Hidroliksan, Türkiye de ve Dünya da daha büyük işler yapmak için yatırımlarına devam edecek ve marka değerini gün geçtikçe arttıracaktır.

About us



Company Hidroliksan established in 1982, continues to manufacture hydraulic presses up to 3.000 ton capacity at the factory of closed area 10.000 sqm.

Hidroliksan is proud to be able to respond to the needs of the following sectors which are automotive, agriculture, metal forming, recycling and many others they need to compression in their production.

Hidroliksan, with strong structure, quality management system, educated human resources and technology that produces high-quality solutions, has earned the confidence of the whole world.

Hidroliksan who closely follow up technological developments that dedicated to its production, in the world, is present to customers a good support before and after sales with high quality products, reasonable prices and timely delivery.

Hidroliksan has been exporting more than 40 countries which are especially in Europe, Middle East, West Africa and Asia with the dealer networks. Main activity for the promotions in these countries, is exhibitions. Hidroliksan gives importance to promotions, participates more than twenty exhibitions per a year with his dealers or directly.

Main products produced with the new technological developments are;

- Workshop Presses up to 1000 Ton capacity
- Deep Drawing / Double Action Presses up to 3000 Ton capacity
- Single Action Presses up to 3000 Ton capacity
- Column Frame Presses up to 1000 Ton capacity
- C Frame Presses up to 500 Ton Capacity

In addition to these products, it is included many other hydraulic components and products such as bending presses, hose crimping presses, bronchial presses in the production range.

Changing and developing company Hidroliksan will continue to invest and enhance its brand value day by day, in order to do good things for Turkey and all over the world.





ATÖLYE TiPi PRESLER HYDRAULIC WORKSHOP PRESSES

Atölye TiPi Presler (Model HD)

Hidroliksan Atölye tipi Presler, standart ölçüde olmakla beraber, müşteri ihtiyacına göre de üretilebilir. Bu tip presler otomatik ve manual olmak üzere 1000 ton kapasiteye kadar üretilebilir. Hidroliksan atölye tipi presler CE standartlarına göre üretilmekte olup, kullanıcının makine kullanımına ve bakımına yardımcı olacak kullanma klavuzu içermektedir.

Atölye tipi presler daha çok tamir ve bakım atölyelerinde kullanılmakta olup, ufak çapta büküm, delik delme, doğrultma ve bilye çıkarma işlerinde kullanılmaktadır.

Workshop Presses :

Workshop-Type Presses are standard-type presses, as well as measured according to customer purpose. Workshop-type presses can be manufactured up to 1000 tons in automatic and manual as optional. All Hidroliksan Workshop Presses comply with the strictest regulatory requirements, meeting the European CE standards. Each Hidroliksan Workshop Press includes a comprehensive manual, supporting our end users in use and maintenance of our products.

Hidroliksan Workshop Type Presses are used mostly in repair and maintenance workshops for the small bending, punching, straightening, detruing / extracting (removing)

Motorlu, Kollu ve Gezer Silindirli

Motor and Hand Operated with Movable Cylinder

Teknik Özellikler / Technical Specification

	HD. 20 Ton	HD. 30 Ton	HD.30 Ton
Kapasite Capacity	Kollu Manual	Kollu Manual	Motorlu Motor Operated
A (mm)	1800	1800	2250
B (mm)	650	650	850
C (mm)	780	880	1110
D (mm)	490	600	720
E (mm)	200	200	300
H (mm)	700	800	900
Stroke (mm)	150	150	400
Motor (kw.)	-	-	3
Pompa/Pump (Lt.)	-	-	6.5
Ağırlık/Weight (kg.)	175	200	600

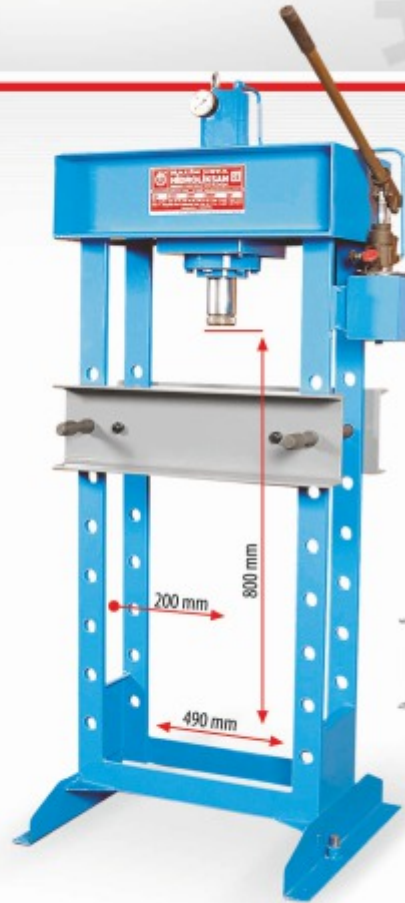

HD/H-20/30 TON
Kollu / Manual

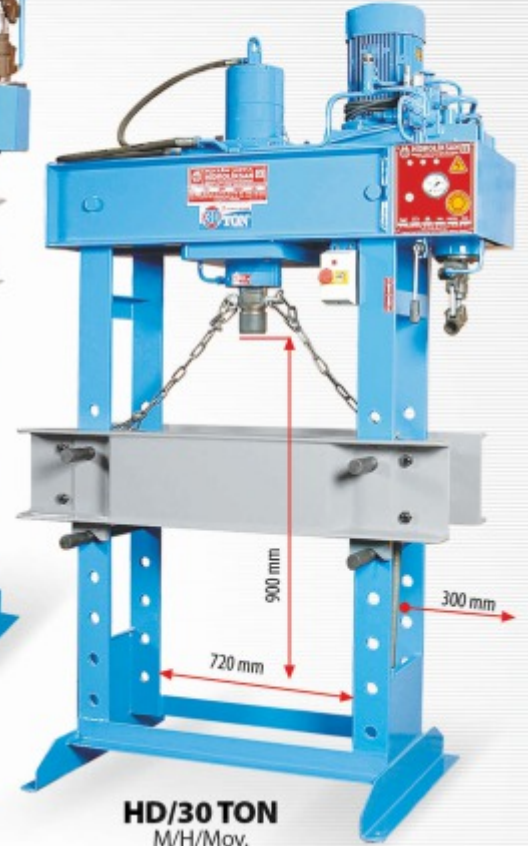

HD/30 TON
M/H/Mov.

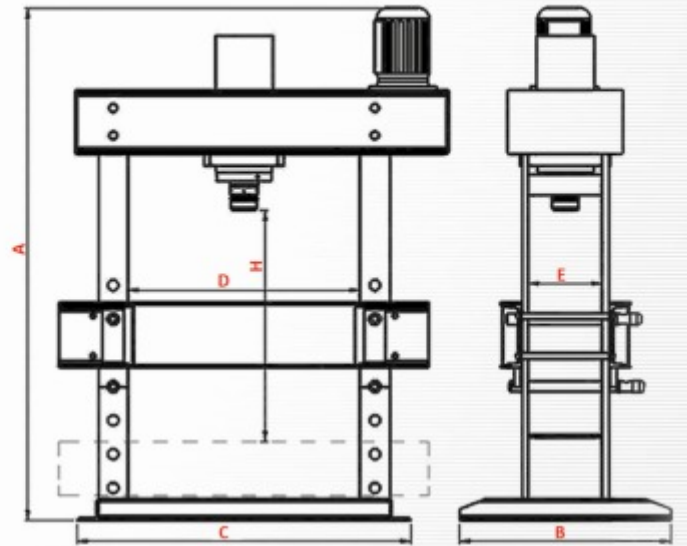

Standart Ekipmanlar / Standart Equipments

Krom Kaplı Silindir / **Chrome Plated Cylinder**
Kaynatılmış Çelik Gövde / **Steel Welded Frame**
Basınç Göstergesi / **Oil Pressure Gauge**
Basınç Ayarı / **Pressure Adjustment**
Kullanma Klavuzu / **User Manual**
2 Yıl Garanti / **2 Year Warranty**

Opsiyonel Ekipmanlar / Optional Equipments

Basınç Regülatörü / **Pressure Regulator**
V Kalıbı / **V Block**
Otomatik Kontrol / **Automatic Control**
Ayak Pedalı / **Foot Pedal**
Tabla / **Table**

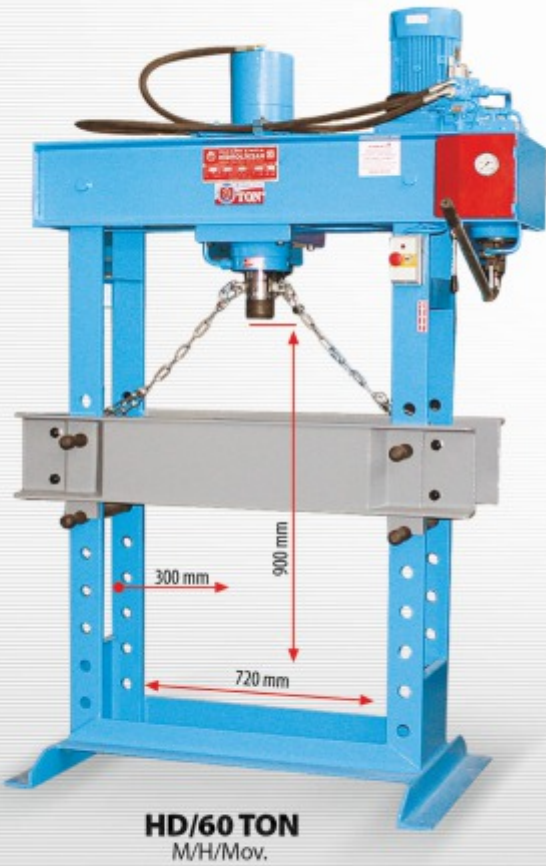
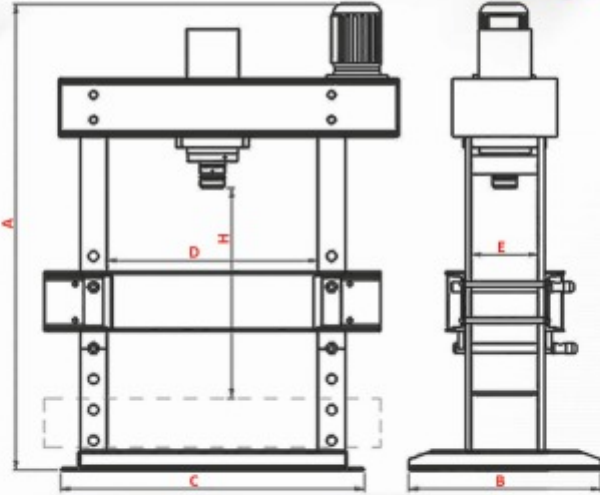
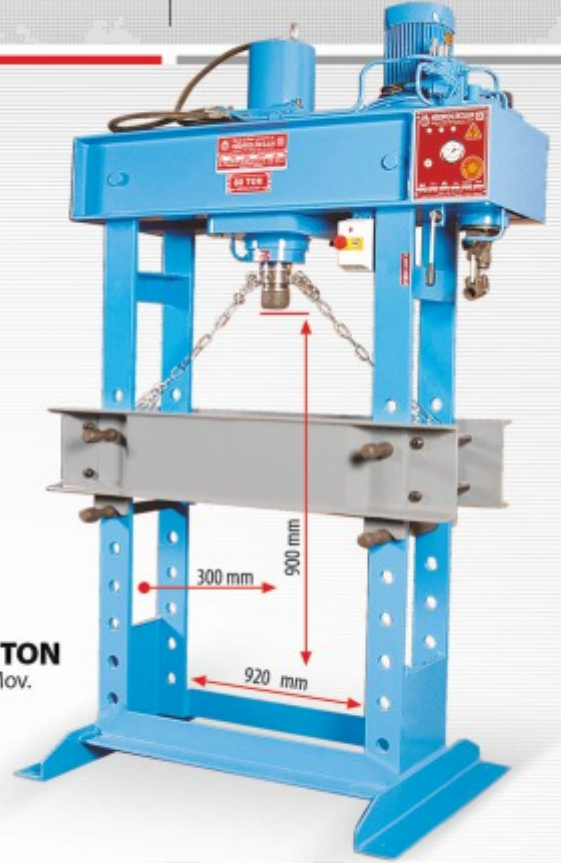
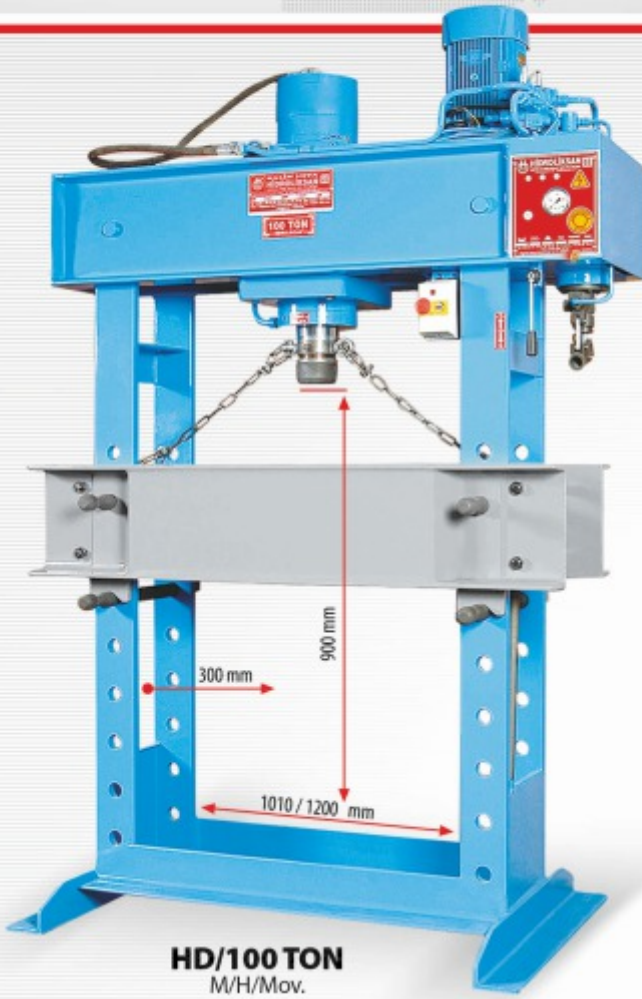

Motorlu, Kollu ve Gezer Silindirli

Motor and Hand Operated with Movable Cylinder

Teknik Özellikler / Technical Specification

	HD. 60 Ton	HD. 80 Ton	HD.100 Ton
Kapasite Capacity	Motorlu Motor Operated	Motorlu Motor Operated	Motorlu Motor Operated
A (mm)	2250	2350	2400
B (mm)	850	850	850
C (mm)	1200	1350	1460
D (mm)	820	920	1010
E (mm)	300	300	300
H (mm)	900	900	900
Stroke (mm)	400	400	400
Motor (kw.)	3	3	4
Pompa/Pump (Lt.)	6.5	6.5	11
Ağırlık/Weight (kg.)	675	725	900



ATÖLYE TİPİ PRESLER
HYDRAULIC WORKSHOP PRESSES



HD/120 TON
M/H/Mov.



HD/160 TON
M/H/Mov.



HD/180 TON
M/H/Mov.

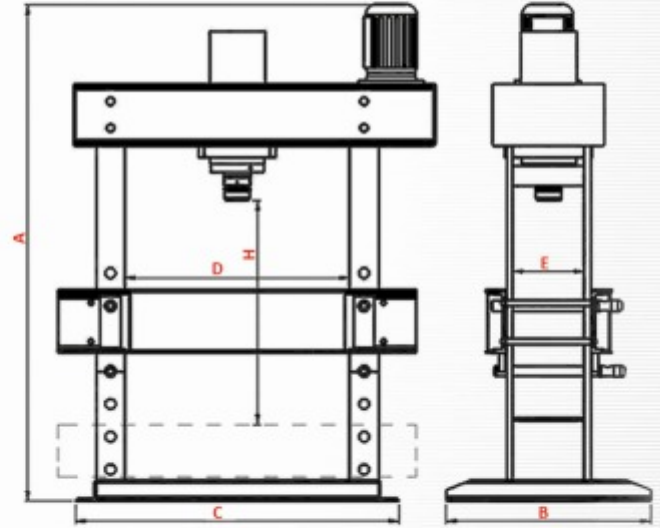

Motorlu, Kollu ve Gezer Silindirli

Motor and Hand Operated with Movable Cylinder

Teknik Özellikler / Technical Specification

	HD. 120 Ton	HD. 160 Ton	HD.180 Ton
Kapasite Capacity	Motorlu Motor Operated	Motorlu Motor Operated	Motorlu Motor Operated
A (mm)	2400	2550	2750
B (mm)	950	950	1200
C (mm)	1660	1580	2150
D (mm)	1200	1100	1550
E (mm)	400	350	550
H (mm)	900	900	900
Stroke (mm)	400	400	400
Motor (kw.)	4	5.5	7.5
Pompa/Pump (Lt.)	11	15	22
Ağırlık/Weight (kg.)	1250	1300	1600

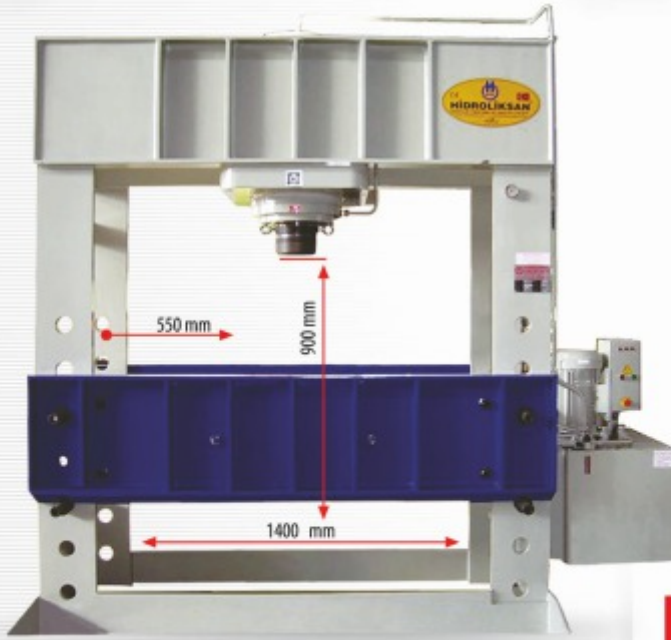
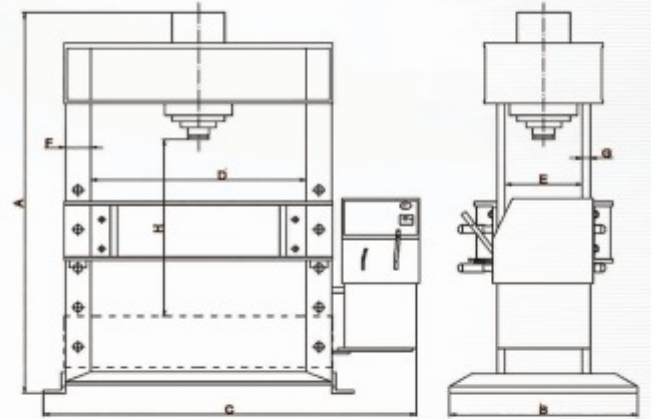
**HD/200 TON****HD/250 TON****HD/300 TON**

Motorlu Motor Operated

Teknik Özellikler / Technical Specification

Kapasite Capacity	(TON)	200	250	300
A Yükseklik / Height	(mm)	2800	2550	3000
B Ayak Boyu / Base Length	(mm)	1200	1200	1300
C Pres Genişliği / Press Wideness	(mm)	2000	2020	2450
D İki Sütun Arası / Between Two Columns	(mm)	1300	1300	1400
E İki Sütun Arası (En) / Between Two Columns (Width)	(mm)	450	450	550
H İş Alma Kapasitesi / Working Capacity	(mm)	900	900	900
Piston Stroku / Piston Stroke	(mm)	400	400	400
Hidrolik Pompa / Hydraulic Pump	(lt)	22	34.5	48
Motor Gücü / Motor Power	(kw.)	7.5	15	15
Toplam Ağırlığı / Total Weight	(kg)	2300	2600	4000

Standart Ekipmanlar / Standart Equipments

Krom Kaplı Silindir / Chrome Plated Cylinder
Kaynatılmış Çelik Gövde / Steel Welded Frame
Basınç Göstergesi / Oil Pressure Gauge
Basınç Ayarı / Pressure Adjustment
Kullanma Klavuzu / User Manual
2 Yıl Garanti / 2 Year Warranty

Opsiyonel Ekipmanlar / Optional Equipments

Basınç Regülatörü / Pressure Regulator
V Kalıbı / V Block
Otomatik Kontrol / Automatic Control
Ayak Pedalı / Foot Pedal
Tabla / Table
Gezer Silindir / Movable Cylinder



1000 Ton'a kadar
Up to 1000 Ton

ATÖLYE TİPİ PRESLER
HYDRAULIC WORKSHOP PRESSES



HD/400 TON

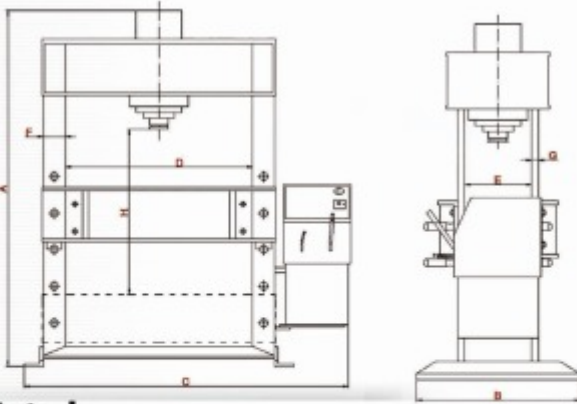

Motorlu

Motor Operated

Teknik Özellikler / Technical Specification

Kapasite Capacity	(TON)	400	500	600
A Yükseklik / Height	(mm)	3100	3300	3300
B Ayak Boyu / Base Length	(mm)	1300	1300	1300
C Pres Genişliği / Press Wideness	(mm)	2500	2500	2500
D İki Sütun Arası / Between Two Columns	(mm)	1400	1400	1400
E İki Sütun Arası (En) / Between Two Columns (Width)	(mm)	550	550	550
F Sütun En / Column Width	(mm)	300	300	300
G Sütun Kalınlığı / Column Thickness	(mm)	50	50	50
H İş Alma Kapasitesi / Working Capacity	(mm)	900	900	900
Piston Stroku / Piston Stroke	(mm)	400	400	400
Hydrolik Pompa / Hydraulic Pump	(lt)	60	67	100
Motor Gücü / Motor Power	(kw.)	30	30	40
Toplam Ağırlığı / Total Weight	(kg)	6000	6500	7000



HD/500 TON



HD/600 TON

Standart Ekipmanlar / Standart Equipments

Krom Kaplı Silindir / **Chrome Plated Cylinder**
Kaynatılmış Çelik Gövde / **Steel Welded Frame**
Basınç Göstergesi / **Oil Pressure Gauge**
Basınç Ayarı / **Pressure Adjustment**
Kullanma Klavuzu / **User Manual**
2 Yıl Garanti / **2 Year Warranty**

Opsiyonel Ekipmanlar / Optional Equipments

Basınç Regülatörü / **Pressure Regulator**
V Kalıbı / **V Block**
Otomatik Kontrol / **Automatic Control**
Ayak Pedali / **Foot Pedal**
Tabla / **Table**
Gezer Silindir / **Movable Cylinder**

TABLALI ATÖLYE TİPİ PRESLER

HYDRAULIC WORKSHOP PRESSES WITH TABLE (ECO MODEL)

MODEL HDT

**Model : HDT/100-300****Teknik Özellikler / Technical Specification**

Model	HDT / 100	HDT / 150	HDT / 200	HDT / 250	HDT / 300
Kapasite / Capacity (Ton)	100	150	200	250	300
Table Ölçüsü / Table Size	800X600	1000X600	1200X600	1500X600	1500X600
Strok / Stroke (mm)	400	400	400	400	400
İş alma Boyu / Day Light (mm)	600	600	600	600	600
Motor Gücü / Motor Power (KW)	4	5,5	15	15	15
Pompa / Pump / (litre/liters)	11	15	34	45	60
İniş Hızı / Down Speed (mm/s)	7	6	9	11	13
Dönüş Hızı / Return Speed (mm/s)	13	10	17	19	26
Çalışma Hızı / Working Speed (mm/s)	7	7	9	11	13
Uzunluk / Length (mm)	1000	1000	1200	1200	1300
Genişlik / Width (mm)	1300	1400	2500	2700	2700
Yükseklik / Height (mm)	2300	2300	2600	2600	2700
Ağırlık / Weight (kg)	1800	2400	3700	4200	4500

Standart Ekipmanlar/Standart Equipments

Krom Kaplı Silindir / **Chrome Plated Cylinder**
 Kaynatılmış Çelik Gövde / **Steel Welded Frame**
 Otomatik Kontrol Ünitesi / **Automatic Control Unit**
 Çift el Buton ile Kontrol / **Two Hand Button Control**
 Basınç Regülatörü / **Pressure Regulator**
 Basınç Göstergesi / **Oil Pressure Gauge**
 T Kanallı Tabla / **T-Slotted Table**
 Kullanma Klavuzu / **User Manual**
 1 Yıl Garanti / **1 Year Warranty**

Opsiyonel Ekipmanlar / Optional Equipments

Kalıp / **Tool**
 Koruma Kapağı ve Işık Bariyeri / **Safety Cover and Light Barrier**



HİDROLİK BÜKÜM PRESLERİ
HYDRAULIC PRESS BRAKE

MODEL HPB

100-300 TON

OTOMATİK
AUTOMATIC



HPB/250 TON

Teknik Özellikler / Technical Specification

Silindir / Cylinder	Ø 200x2
Motor / Motor	11 kw. – 15 Hp.
Pompa / Pump	33 Litre – Liter Tandhem
Büküm Boyu / Bending Length	2000 mm
Büküm Kalınlığı / Bending Thickness	7mm
Strok	400mm

MANUEL
MANUAL

Teknik Özellikler / Technical Specification

Silindir / Cylinder	Ø 220
Motor / Motor	4 kw. – 5.5 Hp.
Pompa / Pump	11 Litre – Liter
Büküm Boyu / Bending Length	1200 mm
Büküm Kalınlığı / Bending Thickness	7 mm
Strok	400 mm



HPB/160 TON



HİDROLİK HORTUM SIKMA PRESLERİ HYDRAULIC HOSE CRIMPING PRESSES



MODEL HCP 101

Teknik Detaylar / Technical Parameters

Model HCP 101

Otomatik Kontrol / Automatic control system

Ayak Pedal / Foot pedal

Sıkma Çapı / Crimping Inside Diameter	: Ø14.5 mm to 101 mm
Max. Açıklık / Max. Opening	: 115mm
Sıkma Hassasiyeti / Crimping precision	: 0.02mm
Nominal Basınç / Rated Pressure	: 30 Mpa
Güç / Power	: 4KW
Voltaj / Voltage	: 380V 50Hz
Nominal Debi / Rated Flow	: 11 L/min
Kalıp/ Die	: 12 dies
Ölçüler / Dimensions	: 1200 x 600 x 1200 LxWxH mm
Ağırlık / Weight	: 700Kg

HCP101 HORTUM SIKMA PRESİ HOSE CRIMPING PRESS

Kalıp Çap mm Ø Mold dia. mm Ø	Kalıp Uzunluk Mold Length
14,5	80
17,5	80
19	80
22,5	80
25	80
29	80
34,5	80
41,5	80
54	80
61	80
70	80
86	80



Model HCP 72

Teknik Detaylar / Technical Parameters

Hortum Sıkma Presi / Hose Crimping Machine

Otomatik Kontrol / Automatic control system

Ayak Pedalı / Foot pedal

Kalıplar / Tools

Sıkma Çapı / Crimping Inside Diameter	: Ø10mm to 72 mm
Max. Açıklık / Max. Opening	: 120 mm
Sıkma Hassasiyeti / Crimping precision	: 0.02mm
Nominal Basınç / Rated Pressure	: 30 Mpa
Güç / Power	: 4KW
Voltaj / Voltage	: 380V 50Hz
Nominal Debi / Rated Flow	: 14 L/min
Kalıp/ Die	: 10 dies
Ölçüler / Dimensions	: 800 x 620 x 1300 LxWxH mm
Ağırlık / Weight	: 380 Kg



HCP72 HORTUM SIKMA PRESİ HOSE CRIMPING PRESS

Kalıp Çap mm Ø Mold dia. mm Ø	Kalıp Uzunluk Mold Length
10	60
16	60
19	60
23	60
26	60
30	70
34	70
38	70
45	70
52	80
63	80
72	80

MODEL HCP72



HİDROLİK C TİPİ PRESLER | MODEL CFS

HYDRAULIC C FRAME PRESSES

C Tipi Presler :

500 Ton kapasiteye kadar üretilen Hidroliksan C tipi Presler, standart ölçüde olmakla beraber, müşteri ihtiyacına göre de üretilebilir. C Tipi presler kullanılan kalıba göre, büküm yapmak, delik delmek, kesim ve doğrultma yapmak için kullanılabilir. 3 tarafı açık olduğu için kalıp takma ve sökme kolayca yapılabilir. Daha çok ufak kalıpla çalışan kullanıcıların tercihi olan C Tipi presler otomatik ve manual olmak üzere üretilmektedir.



C Frame Presses :

Hidroliksan C Frame presses produced up to 500 ton, are standart type presses as well as can be produced according to customer purpose. C Frame presses are using for bending, punching, cutting and straightening according to using tools. Fastening and removing of the tools can be made easily so that 3 sides of press is open... C Frame presses which have using options as manual and automatic, are preferred mostly users who, they are working with small tools.



C Tipi Tek Tesirli Hidrolik Presler | MODEL CFS

C Frame Single Action Presses

Teknik Özellikler / Technical Specification

Model	CFS / 30	CFS / 60	CFS / 100	CFS / 150	CFS / 200	CFS / 250
Kapasite / Capacity (Ton)	30	60	100	150	200	250
Table Ölçüsü / Table Size	500x500	500x500	600x500	800x600	900x600	1000x600
Strok / Stroke (mm)	400	400	400	400	400	400
İş alma Boyu / Day Light (mm)	400	400	400	400	400	400
Motor Gücü / Motor Power (KW)	4	4	4	5,5	11	11
Pompa / Pump / (litre/liters)	9	12+6	20+9	33+9	32+16	44+16
İniş Hızı / Down Speed (mm/s)	10	12	12	12	9	9
Dönüş Hızı / Return Speed (mm/s)	17	21	18	21	18	18
Çalışma Hızı / Working Speed (mm/s)	10	4	4	3	3	3
Uzunluk / Length (mm)	1500	1500	1700	1600	1800	1800
Genişlik / Width (mm)	1000	1000	1100	1100	1200	1200
Yükseklik / Height (mm)	2300	2300	2700	3000	3400	3400
Ağırlık / Weight (kg)	2000	2400	5000	10000	13000	14000



CFS 60 TON

Standart Ekipmanlar / Standart Equipments

Krom Kaplı Silindir / **Chrome Plated Cylinder**
Kaynatılmış Çelik Gövde / **Steel Welded Frame**
Otomatik Kontrol Ünitesi / **Automatic Control Unit**
Koruma Kapağı ve Işık Bariyeri / **Safety cover and Light Barrier**
Çift el Buton ile Kontrol / **Two Hand Button Control**
Basınç Göstergesi / **Oil Pressure Gauge**
Basınç Ayarı / **Pressure Adjustment**
T Kanallı Tabla / **T-Slotted Table**
Kullanma Klavuzu / **User Manual**
1 Yıl Garanti / **1 Year Warranty**

Opsiyonel Ekipmanlar / Optional Equipments

Kalıp / **Tool**
Çıkartıcı Silindir / **Ejector Cylinder**
Hız ayarı / **Speeds Adjustment**
NC kontrol / **NC control**

HİDROLİK C TİPİ PRESLER
HYDRAULIC C FRAME PRESSES



CFS 30 TON



CFS 100-150 TON

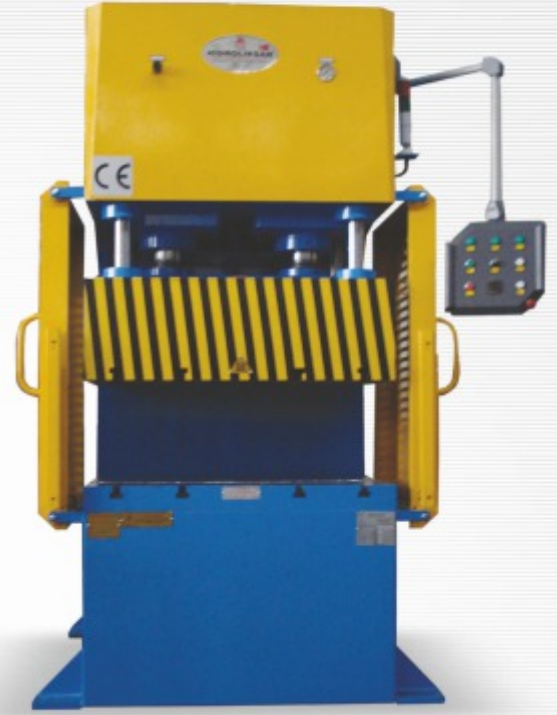

CFS 200 - 250 TON

HİDROLİK C TİPİ ÖZEL PRESLER / HYDRAULIC C FRAME SPECIAL PRESSES

Seri Hiz.
High Speed // Rapid Cycle



CFFS 60 TON
(PLC Kontrol/Control)



C Tipi Doğrultma Presi
C Frame Straightening Press



C Tipi Pres (Büküm Kalıbı ile beraber)
C Frame Presses (with bending tool)



HiDROLiK C TiPi SiVAMA PRESLER
HYDRAULIC C FRAME DEEP DRAWING PRESSES

MODEL CFDD

C Tipi Sivama Presleri:

500 Ton kapasiteye kadar üretilen Hidroliksan C tipi Presler, standart ölçüde olmakla beraber, müşteri ihtiyacına göre de üretilebilir. C Tipi presler kullanılan kalıba göre, büküm yapmak, delik delmek, kesim ve doğrultma yapmak için kullanılabilir. 3 tarafı açık olduğu için kalıp takma ve sökme kolayca yapılabilir. Daha çok ufak kalıpla çalışan kullanıcıların tercihi olan C Tipi presler otomatik ve manual olmak üzere üretilmektedir.



C Frame Deep Drawing Presses :

Hidroliksan C Frame presses produced up to 500 ton, are standart type presses as well as can be produced according to customer purpose. C Frame presses are using for bending, punching, cutting and straightening according to using tools. Fastening and removing of the tools can be made easily so that 3 sides of press is open... C Frame presses which have using options as manual and automatic, are preferred mostly users who, they are working with small tools.



Standart Ekipmanlar/Standart Equipments

Krom Kaplı Silindir / **Chrome Plated Cylinder**
Kaynatılmış Çelik Gövde / **Steel Welded Frame**
Otomatik Kontrol Ünitesi / **Automatic Control Unit**
Koruma Kapağı ve Işık Bariyeri / **Safety Cover and Light Barrier**
Çift el Buton ile Kontrol / **Two Hand Button Control**
Basınç Göstergesi / **Oil Pressure Gauge**
Yağlama / **Lubrication**
Basınç Ayarı / **Pressure Adjustment**
T Kanallı Tabla / **T-Slotted Table**
Kullanma Klavuzu / **User Manual**
1 Yıl Garanti / **1 Year Warranty**

Opsiyonel Ekipmanlar / Optional Equipments

Kalıp / **Tool**
Çıkartıcı Silindir / **Ejector Cylinder**
Hız Ayarı / **Speeds Adjustment**
NC Kontrol / **NC control**



CFDD 100 TON



PLC
Kontrol / Control
Dokunmatik Ekran / Touch Screen



500 Ton'a kadar
Up to 500 Ton

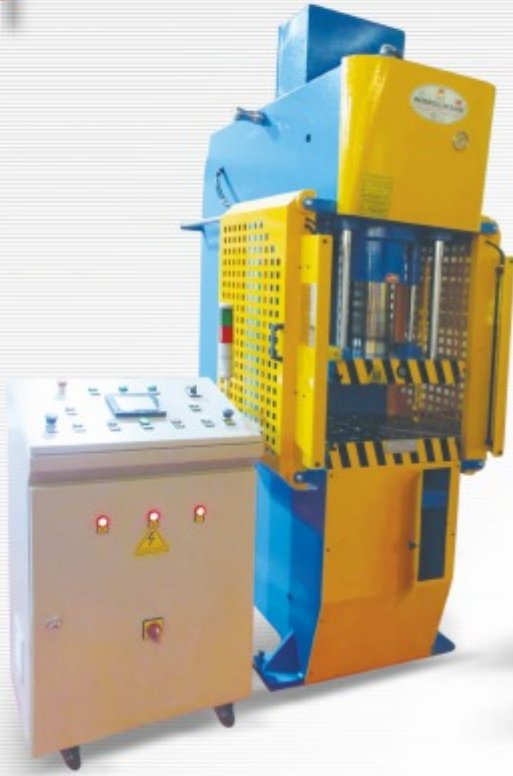

CFDD 30-60 TON



CFDD 150 TON



CFDD 200-250 TON

C Tipi Sıvama Presler

C Frame Deep Drawing Presses

MODEL CFDD

Teknik Özellikler / Technical Specification

Model	CFDD /30	CFDD /60	CFDD /100	CFDD /150	CFDD /200	CFDD /250
Kapasite / Capacity (Ton)	30	60	100	150	200	250
Table Ölçüsü / Table Size	500 X 500	500X500	600X500	800X600	900X600	1000X600
Strok / Stroke (mm)	400	400	400	400	400	400
İş alma Boyu / Day Light (mm)	500	500	500	500	500	500
Motor Gücü / Motor Power (KW)	5.5	7.5	15	18	22	22
İniş Hızı / Down Speed (mm/s)	100	116	107	131	107	131
Dönüş Hızı / Return Speed (mm/s)	100	126	156	123	156	123
Çalışma Hızı / Working Speed (mm/s)	12,5	10	10	10	10	10
CUSHION CYLINDER / POT SİLİNDİR						
Kapasite / Capacity (Ton)	10	20	30	50	60	80
Stroke / Stroke (mm)	150	150	150	150	150	150
İniş Hızı / Cushion Down Speed (mm/s)	58	50	48	39	48	39
Dönüş Hızı / Cushion Return Speed (mm/s)	30	28	24	47	24	47
Uzunluk / Lenght (mm)	1500	1500	1700	1600	1800	1800
Genişlik / Width (mm)	1000	1000	1100	1100	1200	1200
Yükseklik / Height (mm)	2600	2600	3000	3200	3600	3700
Ağırlık / Weight (kg)	2400	2900	6000	11000	14000	14500



HİDROLİK H TİPİ TEK TESİRLİ PRESLER
HYDRAULIC H FRAME SINGLE ACTION PRESSES



HSA 500 - 600 TON



HSA 100 TON

3000 Ton'a kadar
Up to 3000 Ton

H TİPİ TEK TESİRLİ PRESLER **MODEL HSA**
H Type Single Action Presses

Teknik Özellikler / Technical Specification

Model	HSA / 100	HSA / 200	HSA / 300	HSA / 400	HSA / 500	HSA / 600
Kapasite / Capacity (Ton)	100	200	300	400	500	600
Table Ölçüsü / Table Size	800x1000	800 x 1000	1000x1200	1200x1400	1200x1500	1500x1700
Strok / Stroke (mm)	1000	1000	1000	1000	1000	1000
İş alma Boyu / Day Light (mm)	1000	1000	1000	1000	1000	1000
Motor Gücü / Motor Power (KW)	15	22	37	45	55	45+22
İniş Hızı / Down Speed (mm/s)	100	116	107	131	95	91
Dönüş Hızı / Return Speed (mm/s)	115	126	156	123	100	100
Çalışma Hızı / Working Speed (mm/s)	10	10	10	10	10	10



HSA 200 TON

HİDROLİK H TİPİ TEK TESİRLİ PRESLER
HYDRAULIC H FRAME SINGLE ACTION PRESSES



HSA 300 TON



HSA 400 TON

Standart Ekipmanlar / Standart Equipments

- Krom Kaplı Silindir / **Chrome Plated Cylinder**
- Kaynatılmış Çelik Gövde / **Steel Welded Frame**
- Otomatik Kontrol Ünitesi / **Automatic Control Unit**
- Koruma Kapağı ve Işık Bariyeri / **Safety cover and Light Barrier**
- Çift el Buton ile Kontrol / **Two Hand button control**
- Basınç Göstergesi / **Oil Pressure Gauge**
- Yağlama / **Lubrication**
- Basınç Ayarı / **Pressure Adjustment**
- T Kanallı Tabla / **T-Slotted Table**
- Kullanma Klavuzu / **User Manual**
- 1 Yıl Garanti / **1 Year Warranty**

Opsiyonel Ekipmanlar / Optional Equipments

- Kalıp / **Tool**
- Çıkartıcı Silindir / **Ejector Cylinder**
- Hız Ayarı / **Speeds Adjustment**
- NC Kontrol / **NC Control**



HiDROLiK H TiPi SiVAMA PRESLER

HYDRAULIC H FRAME DOUBLE ACTION/DEEP DRAWING PRESSES

MODEL HDD

Sivama / Çift Tesrli Presler :

Sivama presler adında anlaşılacağı gibi, sivama gerektiren mutfak gereçleri, el arabası haznesi, ısıtıcı kazanları , tüp gaz üretimi ve bunlar gibi birçok ürünün imalatında kullanılmaktadır. Sivama Presler 3000 Ton'a kadar üretilmekte olup özelliklerde belirtilen bir çok opsiyon sunmaktadır.



Deep Drawing Presses Double Action Presses :

As the name suggests, this press for making deep drawing such as kitchen tools and base of wheel barrow, boiler,lid, bottled gas (tube industry)... etc. Hidroliksan deep drawing presses can be produced up to 3000 Ton in any size and are manufactured with many options as indicated in specifications...



3000 Ton'a kadar
Up to 3000 Ton

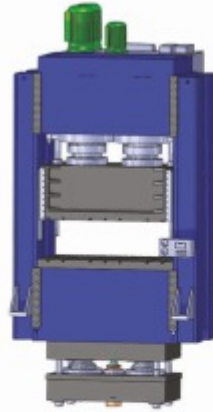

HDD 1000 TON

H TiPi SiVAMA PRESLER

H Frame Deep Drawing Presses

MODEL HDD

Teknik Özellikler / Technical Specification

Model	HDD / 100	HDD / 200	HDD / 300	HDD / 400	HDD / 500	HDD / 600
Kapasite / Capacity (Ton)	100	200	300	400	500	600
Table Ölçüsü / Table Size	800x1000	800 x 1000	1000x1200	1200x1400	1200x1500	1500x1700
Strok / Stroke (mm)	1000	1000	1000	1000	1000	1000
İş alma Boyu / Day Light (mm)	1000	1000	1000	1000	1000	1000
Motor Gücü / Motor Power (KW)	15	22	37	45	55	45+22
İniş Hızı / Down Speed (mm/s)	100	116	107	131	95	91
Dönüş Hızı / Return Speed (mm/s)	115	126	156	123	100	100
Çalışma Hızı / Working Speed (mm/s)	10	10	10	10	10	10
CUSHION CYLINDER / POT SİLİNDİR						
Kapasite / Capacity (Ton)	40	65	130	150	200	250
Stroke / Stroke (mm)	300	300	300	300	300	300
İniş Hızı / Cushion Down Speed (mm/s)	58	50	48	39	50	43
Dönüş Hızı / Cushion Return Speed (mm/s)	30	28	24	47	39	39



HDD 300 TON



HDD 200 TON

Standart Ekipmanlar / Standart Equipments

Krom Kaplı Silindir / Chrome Plated Cylinder
Kaynatılmış Çelik Gövde / Steel Welded Frame
Otomatik Kontrol Ünitesi / Automatic Control Unit
Koruma Kapağı ve Işık Bariyeri / Safety Cover and Light Barrier
Çift el Buton ile Kontrol / Two Hand button control
Basınç Göstergesi / Oil pressure gauge
Basınç Ayarı / Pressure Adjustment
T Kanallı Tabla / T-Slotted Table
Kullanma Klavuzu / User Manual
1 Yıl Garanti / 1 Year Warranty

Opsiyonel Ekipmanlar / Optional Equipments

Kalıp / Tool
Çıkartıcı Silindir / Ejector Cylinder
Hız ayarı / Speeds Adjustment
NC kontrol / NC control



HDD 500 - 600 TON





HİDROLİK KOLONLU TEK VE ÇİFT TESİRLİ PRESLER
HYDRAULIC COLUMN FRAME SINGLE/DOUBLE ACTION PRESSES

MODEL HCFP

KOLONLU TEK ve ÇİFT TESİRLİ / SIVAMA PRESLER
Column Frame Single/Double Action/Deep Drawing Presses

Teknik Özellikler / Technical Specification

	HCFP / 100	HCFP / 200	HCFP / 300	HCFP / 400
Kapasite / Capacity (Ton)	100	200	300	400
Table Ölçüsü / Table Size	800x1000	800 x 1000	1000x1200	1200x1400
Strok / Stroke (mm)	1000	1000	1000	1000
İş alma Boyu / Day Light (mm)	1000	1000	1000	1000
Motor Gücü / Motor Power (KW)	15	22	37	45
İniş Hızı / Down Speed (mm/s)	100	116	107	131
Dönüş Hızı / Return Speed (mm/s)	115	126	156	123
Çalışma Hızı / Working Speed (mm/s)	10	10	10	10
Pot / Cushion (Ton) - Opsiyonel / Optional	40	65	130	150
Stroke / Stroke (mm)	300	300	300	300
İniş Hızı / Cushion Down Speed (mm/s)	58	50	48	39
Dönüş Hızı / Cushion Return Speed (m/s)	30	28	24	47



HCFP / D 400 TON

1000 Ton'a kadar
Up to 1000 Ton



HCFP / S 300 TON



HCFP / D 100 - 200 TON

Standart Ekipmanlar/Standart Equipments

Krom Kaplı Silindir / **Chrome Plated Cylinder**
Kaynatılmış Çelik Gövde / **Steel Welden Frame**
Otomatik Kontrol Ünitesi / **Automatic Control Unit**
Koruma Kapağı ve Işık Bariyeri / **Safety Cover and Light Barrier**
Çift el Buton ile Kontrol / **Two Hand button control**
Basınç Göstergesi / **Oil Pressure Gauge**
Yağlama / **Lubrication**
Basınç Ayarı / **Pressure Adjustment**
T Kanallı Tabla / **T-slotted table**
1 Yıl Garanti / **1 Year Warranty**

Opsiyonel Ekipmanlar / Optional Equipments

Kalıp / **Tool**
Çıkartıcı Silindir / **Ejector Cylinder**
Hız Ayarı / **Speeds Adjustment**
NC Kontrol / **NC Control**
Pot / **Cushion**

1000 Ton'a kadar
Up to 1000 Ton

HİDROLİK SAC DESEN PRESLER HYDRAULIC SHEET FORMING PRESSES | MODEL HSF



HSF 500-600 TON



HSF 100-200 TON

Standart Ekipmanlar/Standart Equipments

Krom Kaplı Silindir / Chrome Plated Cylinder
Kaynatılmış Çelik Gövde / Steel Welded Frame
Otomatik Kontrol Ünitesi / Automatic Control Unit
Çift el Buton ile Kontrol / Two Hand button control
Basınç Göstergesi / Oil Pressure Gauge
Yağlama / Lubrication
Basınç Ayarı / Pressure Adjustment
T Kanallı Tabla / T-slotted Table
Kullanma Klavuzu / User Manual
1 Yıl Garanti / 1 Year Warranty

Opsiyonel Ekipmanlar / Optional Equipments

Koruma Kapağı ve Işık Bariyeri / Safety Cover and Light Barrier
Kalıp / Tool
Çıkartıcı Silindir / Ejector Cylinder
Hız Ayarı / Speeds Adjustment
NC Kontrol / NC Control
Sürücü / Feeder

H TİPİ SAC DESEN PRESLER | MODEL HSF

H Type Sheet Forming Presses



HSF 300-400 TON

Teknik Özellikler / Technical Specification

Model	HSF / 200	HSF / 300	HSF / 400	HSF / 500	HSF / 600
Kapasite / Capacity (Ton)	200	300	400	500	600
Table Ölçüsü / Table Size (mm)	550 x 1200	600 x 1400	600 x 1400	1000 x 1600	1000 x 1600
Strok / Stroke (mm)	400	400	400	400	400
İş alma Boyu / Day Light (mm)	600	600	600	600	600
Motor Gücü / Motor Power (KW)	22	37	45	55	45+22
İniş Hızı / Down Speed (mm/s)	116	107	131	95	91
Dönüş Hızı / Return Speed (mm/s)	126	156	123	100	100
Çalışma Hızı / Working Speed (mm/s)	10	10	10	10	10





HiDROLiK H ve KOLONLU TiP SICAK KAÜÇUK PRESLER | MODEL HHRP
HYDRAULIC H/COLUMN FRAME VULCANIZED HOT RUBBER PRESSES

1000 Ton'a kadar
Up to 1000 Ton



2 x 160 TON (Çift Gözlü)
2 x 160 TON (Double Windows)



3 x 100 TON (Üç Gözlü)
3 x 100 TON (Three Windows)



300 TON (Tek Gözlü)
300 TON (Single Window)

H ve KOLONLU TiP TEK/ÇİFT GÖZLÜ HiDROLiK SICAK PRESLER

H/Column Type Single & Multi Windows Vulcanized Hot Rubber Presses

MODEL HHRP

Teknik Özellikler / Technical Specification

Model	HHRP / 100	HHRP / 200	HHRP / 300	HHRP / 400	HHRP / 500	HHRP / 600
Kapasite / Capacity (Ton)	100	200	300	400	500	600
Table Ölçüsü / Table Size	600x600	800 x 800	900x900	1000x1000	1200x1200	1500x1500
Strok / Stroke (mm)	400	400	400	400	400	400
İş alma Boyu / Day Light (mm)	500	500	600	600	800	800
Motor Gücü / Motor Power (KW)	5,5	15	18	18	27	30
Pompa / Pump / (litre/liters)	22	34	60	60	72	81
İniş Hızı / Down Speed (mm/s)	9	8	9	8	6	6
Dönüş Hızı / Return Speed (mm/s)	14	15	27	18	16	16

Standart Ekipmanlar/Standart Equipments

Krom Kaplı Silindir / **Chrome Plated Cylinder**
Kaynatılmış Çelik Gövde / **Steel Welden Frame**
Otomatik Kontrol Ünitesi / **Automatic Control Unit**
Çift el Buton ile Kontrol / **Two Hand Button Control**
Basınç Göstergesi / **Oil Pressure Gauge**
Yağlama / **Lubrication**
Basınç Ayarı / **Pressure Adjustment**
Kullanma Klavuzu / **User Manual**
1 Yıl Garanti / **1 Year Warranty**
Gaz Atma Sistemi / **Bumping System**

Opsiyonel Ekipmanlar / Optional Equipments

Kalıp / **Tool**
Çıkartıcı Silindir / **Ejector Cylinder**
Hız ayarı / **Speeds Adjustment**
NC kontrol / **NC control**
Koruma Kapağı ve Işık Bariyeri / **Safety Cover and Light Barrier**
T Kanallı Tabla / **T-Slotted Table**
Çok Katlı Tabla / **Multi Layer Table**
Çok Gözlü Tabla / **Multi Window Table**



700 TON (Çok Katlı Tabla)
700 TON (Multi Layer Table)



İstirca / Resistance

HİDROLİK TUZ BASMA PRESLERİ PRESLER | MODEL HSBP

HYDRAULIC SALT BLOCK PRESSES

Tuz Basma Presleri:

Hayvanlar için yalama taşı yapımında kullanılır ve bu yalama taşları genellikle, 3,5,7,10,15,20 kg bloklar halindedir.



Hidroliksan Tuz basma Presleri istenilen her kapasiteye uygun olarak üretilmekte olup, istenildiğinde pres makinesi üretim hattına uygun şekilde yapılabilir veya üretim hattı komple tedarik edilebilir.

Salt Block Presses:

It is used to make licking blocks which licking blocks are generally 3,5,7,10,15,20 kgs , for animals (bovine and ovine).



Hidroliksan Salt Block Presses can be manufactured in any capacity requested by user and if demanded, it can be made in accordance with production line using already or can be supplied with a complete production line.



HSBP 300 TON



HSBP 500 TON

Standart Ekipmanlar / Standart Equipments

Krom Kaplı Silindir / **Chrome Plated Cylinder**
 Kaynatılmış Çelik Gövde / **Steel Welden Frame**
 Otomatik Kontrol Ünitesi / **Automatic Control Unit**
 Çift el Buton ile Kontrol / **Two Hand button control**
 Basınç Göstergesi / **Oil pressure gauge**
 Kaıp / **Tool**
 Basınç Ayarı / **Pressure Adjustment**
 Kullanma Klavuzu / **User Manual**
 1 Yıl Garanti/ **1 Year Warranty**

Opsiyonel Ekipmanlar / Optional Equipments

Sürücü / **Feeder**
 Üretim Hattı / **Production Line**
 Koruma Kapağı ve Işık Bariyeri / **Safety Cover and Light Barrier**





HİDROLİK PROFİL BÜKME PRESİ HYDRAULIC CAMBERING PRESS



CNC KONTROL SİSTEMİ / CNC CONTROL SYSTEM



Teknik Özellikler / Technical Specification

Tonaj - Capacity	250 Ton (220 Barda)
Pompa - Pump	Kt6c-14 Paletli Pompa - Palettice Pump
Motor	22 Kw
İleri Hızı - Forward Speed	9 mm/sn
Geri Dönüş Hızı - Return Speed	23 mm/sn
Strok - Stroke	900 mm
İş Alma Kapasitesi - Working Capacity	900 mm
Arka Dayama Boyu - Back Support Lenght	5000 mm

MARKALAMA PRESİ MARKING PRESS

OPSİYONEL
OPTIONAL

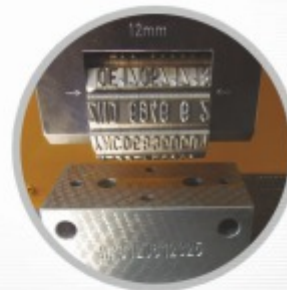

Dayamalar Elektro Mıknatıs Sistemlidir.
Supports Are With Electromagnets System .

Dayama Hareketleri Servo Motor İle Sağlanmaktadır.
Moving Of Support Is Provided With Servo Motor

Sistem Cnc Kontrollü Olup Programlama Yapılabilir.
System Is With Cnc Control And Programming Can Be Done.

Malzeme İlerletme İçin Hareket Sistemi Uzaktan Kumanda Sistemli Olarak Sağlanmaktadır.
Moving System Is Provided With Remote Control For Forwarding Of Material.

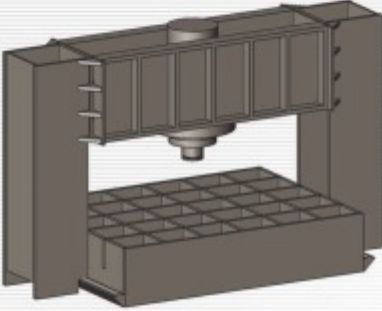
HİDROLİK PLATİNE DOĞRULTMA PRESİ
HYDRAULIC STRAIGHTENING PRESSES**Standart Ekipmanlar / Standart Equipments**Krom Kaplı Silindir / **Chrome Plated Cylinder**Kaynatılmış Çelik Gövde / **Steel Welded Frame**Kumanda ile Kontrol / **Controlled by Pendant**X,Y,Z eksenler Motor hareketli / **X,Y,Z axis movement by motorised**İstenilen Pozisyonda Durabilir / **Stroke Control in any Position**Basınç Göstergesi / **Oil pressure gauge**Basınç Ayarı / **Pressure Adjustment**Tabla / **Table** (Tabla dizaynı isteğe göre - **Table Design according to customer needs**)Kullanma Klavuzu / **User Manual**1 Yıl Garanti / **1 year warranty****HİDROLİK PLATİNE DOĞRULTMA PRESLERİ**

Hydraulic Straightening Presses

MODEL HSPS**Teknik Özellikler / Technical Specification**

Model	HSPS / 100	HSPS / 200	HSPS / 300	HSPS / 400
Kapasite / Capacity (Ton)	100	200	300	400
Table Ölçüsü / Table Size	1000x2000	1000x2500	1500x3000	1500x3500
Strok / Stroke (mm)	400	400	400	400
İş alma Boyu / Day Light (mm)	600	600	600	600
Motor Gücü / Motor Power (KW)	4	7,5	15	18
İniş Hızı / Down Speed (mm/s)	7	7	9	9
Dönüş Hızı / Return Speed (mm/s)	13	10	17	19



HiDROLiK KOMBiNE MAKASLAR
HYDRAULIC IRON WORKERS

MODEL HDK



HDK 45 | 60



Teknik Özellikler ve Standart Donanım
Technical Specifications and Standard Accessories
Zimba ve Matris Ø 22 / **Punch and Die Ø 22**
Zimba Tutucusu / **Punch Holder**
Flanş - Lama Kesme Bıçağı / **Flat Bar Cutting Blade**
Dolu Malzeme Makası / **Solid Round - Square Cutting Blade**
Köşebent Kesme Makası / **Angle Shear**
Çentik Açma Donanımı / **Notching Blade**
Merkezi Yağlama Sistemi / **Central Lubrication System**
Ay Anahtarı / **C - Spanner**
Kullanma Kılavuzu / **User's Manual Book**

BEŞ İŞ İSTASYONU / FIVE WORK STATIONS

* HDK 45
** HDK 60

<p>1- DELİK ZIMBASI Makinanın zimba kısmında Ø38 mm çapa kadar (8"-11" mm kalınlıkta) çok temiz delik delme ve zimbalama işlemleri yapılabilir. Zimbasi ve matrisi kolay değiştirilebilir. Özel zimbalar çok kısa sürede firmamızdan temin edilebilir.</p>	<p>1- PUNCHING With the punching tool, holes and punches up to Ø 38 mm (in 8" - 11" mm thickness) can be made easily and efficiently. The punches and dies are interchangeable and easy to change. Special tools and punches are available upon request.</p>
<p>2- DOLU MALZEME MAKASI Makinanın bu bölümünde 30"-40" mm'ye kadar dolu yuvarlak ve 25"-35" mm dolu kare malzemeler çok hızlı bir şekilde kesilebilir. Bıçaklar değiştirilerek U-1 ve T Profillerde kesilebilir. Özel bıçaklar firmamızdan temin edilebilir.</p>	<p>2- STEEL BAR SHEARING With this part of the machine 25" - 35" mm square and round up to 30" - 40" mm can be cut quickly. By changing the blades you can also cut U - I or T Sections. Special blades are available upon request.</p>
<p>3- KÖŞEBENT KESME MAKASI Burada özel Z formundaki bıçaklar sayesinde çeşitli ebatlarda köşebentleri 90° 45° kesebilirsiniz.</p>	<p>3- ANGLE SHEAR Here with the help of special Z Form Blades you can cut the several 90° and 45° angle sections efficiently.</p>
<p>4- SAC MAKASI Çok çeşitli gündelik sac kesme işlemlerinizi burada 300 mm bıçak sayesinde hızlı yapabilirsiniz.</p>	<p>4- SHEET METAL SHEAR With the 300 mm blade you can cut daily sheet metal cutting jobs very easily.</p>
<p>5- KÖŞE KESME VE ÇENTİK AÇMA Makina ile gelen dikdörtgen çentik kalıbı ile köşe açma ve çentik işlemlerinizi çok temiz şekilde yapabilirsiniz. Özel çentik işleri için gereken kalıplar firmamızdan temin edilebilir.</p>	<p>5- NOTCHING The machine comes with a rectangular notching tool which you can use for general purpose. Special V notching tools are also available upon request.</p>



(Opsiyonel / Optional)
Hidrolik Stripsiz Sistemi
Hydraulic Stripper

BEŞ İŞ İSTASYONU / FIVE WORK STATIONS

* HDK 65
** HDK 85

<p>1- DELİK ZIMBASI Makinanın zimba kısmında 57 mm çapa kadar (10" - 12" mm kalınlıkta) çok temiz delik delme ve zimbalama işlemleri yapılır. Zimbasi ve matrisi kolay değiştirilebilir. Özel zimbalar çok kısa sürede firmamızdan temin edilebilir.</p>	<p>1- PUNCHING With the punching tool, holes and punches up to Ø 57 mm (in 10" - 12" mm thickness) can be made easily and efficiently. The punches and dies are interchangeable and easy to change. Special tools and punches are available upon request.</p>
<p>2- DOLU MALZEME MAKASI Makinanın bu bölümünde 45" - 50" mm'ye kadar dolu yuvarlak ve 45" - 50" mm dolu kare malzemeler çok hızlı bir şekilde kesilebilir. Bıçaklar değiştirilerek U-1 ve T Profillerde kesilebilir. Özel bıçaklar firmamızdan temin edilebilir.</p>	<p>2- STEEL BAR SHEARING With this part of the machine 45" - 50" mm square and round up to 45" - 50" mm can be cut quickly. By changing the blades you can also cut U - I or T Sections. Special blades are available upon request.</p>
<p>3- KÖŞEBENT KESME MAKASI Burada özel bıçaklar sayesinde çeşitli ebatlarda köşebentleri 90° 45° kesebilirsiniz.</p>	<p>3- ANGLE SHEAR Here with the help of special Blades you can cut several type of 90° and 45° angle sections efficiently.</p>
<p>4- SAC MAKASI Çok çeşitli gündelik sac kesme işlemlerinizi burada 375" - 480" mm bıçak sayesinde hızlı yapabilirsiniz.</p>	<p>4- SHEET METAL SHEAR You can cut daily sheet metal cutting jobs very easily with 375" - 480" mm shear.</p>
<p>5- KÖŞE KESME VE ÇENTİK AÇMA Makina ile gelen dikdörtgen çentik kalıbı ile köşe açma ve çentik işlemlerinizi çok temiz şekilde yapabilirsiniz. Özel çentik işleri için gereken kalıplar firmamızdan temin edilebilir.</p>	<p>5- NOTCHING The machine comes with a rectangular notching tool which you can use for general purpose. Special V-notching tools are also available upon request.</p>





HDK 55 | 65 | 85

Teknik Özellikler ve Standart Donanım Technical Specifications and Standard Accessories

Zımba ve Matris Ø 22 / Punch and Die Ø 22
Zımba Tutucusu / Punch Holder
Flanş - Lama Kesme Bıçağı / Flat Bar Cutting Blade
Dolu Malzeme Makası / Solid round - Square Cutting Blade
Köşebent Kesme Makası / Angle Shear
Çentik Açma Donanımı / Notching Blade
Çalışma Lambası / Working Light
Merkezi Yağlama Sistemi / Central Lubrication System
Elektrikli Arka Dayama / Electrical Back gauge
Ay Anahtarı / C - Spanner
Kullanma Kılavuzu / User's Manual Book

BEŞ İŞ İSTASYONU / FIVE WORK STATIONS

HDK 115

1- DELİK ZIMBASI

Makinanın zımba kısmında 55 mm çapa kadar (16 mm kalınlıkta) çok temiz delik delme ve zımbalama işlemleri yapılır. Zımbası ve matrisi kolay değiştirilebilir. Özel zımbalar çok kısa sürede firmamızdan temin edilebilir.

2- DOLU MALZEME MAKASI

Makinanın bu bölümünde 55 mm'ye kadar dolu yuvarlak ve 50 mm dolu kare malzemeler çok hızlı bir şekilde kesilebilir. Bıçaklar değiştirilerek U-I ve T Profillerde kesilebilir. Özel bıçaklar firmamızdan temin edilebilir.

3- KÖŞEBENT KESME MAKASI

Burada özel bıçaklar sayesinde çeşitli ebatlarda köşebentleri 90° 45° kesebilirsiniz.

4- SAC MAKASI

Çok çeşitli gündelik sac kesme işlemlerinizi burada uzun bıçak sayesinde hızlı yapabilirsiniz.

5- KÖŞE KESME VE ÇENTİK AÇMA

Makina ile gelen dikdörtgen çentik kalıbı ile köşe açma ve çentik işlemlerinizi çok temiz şekilde yapabilirsiniz. Özel çentik işleri için gereken kalıplar firmamızdan temin edilebilir.

1-PUNCHING

With the punching tool, holes and punches up to Ø 55 mm (in 16 mm thickness) can be punch easily and efficiently. The punches and dies are interchangeable and easy to change Special tools and punches are available upon request.

2- STEEL BAR SHEARING

With this part of the machine 50 mm square and round up to 55 mm can be cut quickly. By changing the blades you can also cut U - I or T Sections. Special blades are available upon request.

3- ANGLE SHEAR

Here with the help of special Blades you can cut several type of 90° and 45° angle sections efficiently.

4- SHEET METAL SHEAR

You can cut daily sheet metal cutting jobs very easily.

5- NOTCHING

The machine comes with a rectangular notching tool which you can use for general purpose Special V- notching tools are also available upon request.

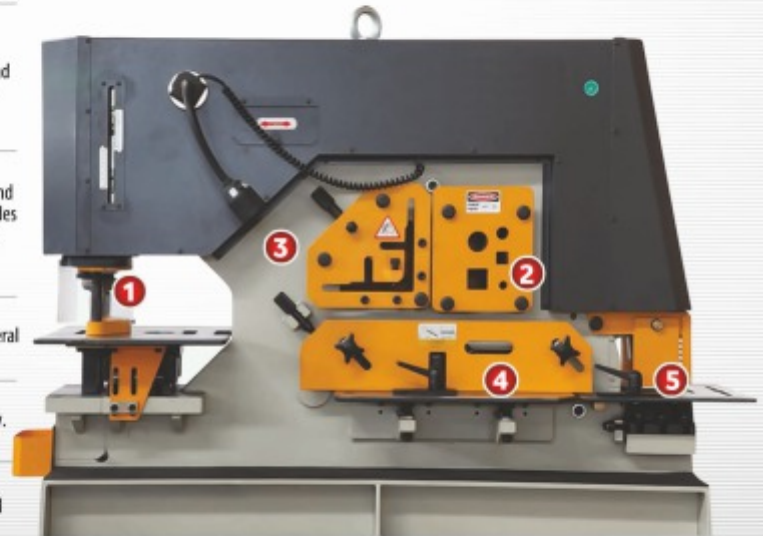

Available on models
HDK 55 / 65 / 85 / 115 / 175
Standart / Standard
Elektrikli Arka Dayama
Electrical Back Gauge



(Opsiyonel / Optional)
Hidrolik Sıyıcı Sistemi
Hydraulic Stripper





HİDROLİKSAN® HALİM USTA

HİDROLİK PRES İML. SAN. TİC. LTD. ŞTİ.

1. Organize Sanayi İstikamet Cd.

No: 24 - 42300 KONYA / TÜRKİYE

Tel: +90 332 251 73 40 - 251 48 52 - 251 74 64

Fax: +90 332 251 73 41

www.hidroliksan.com - info@hidroliksan.com

