



SAPHIR



RFS 350x450 ENC HORIZONTAL AUTO BAND SAW MACHINE

*Photo may feature machine with optional accessories

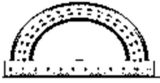
CUTTING CAPACITY

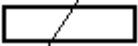
	0°
	350 mm
	330 mm
	330 x 450 mm

TECHNICAL SPECIFICATIONS

<i>Main Motor</i>	: 4 kW
<i>Gearbox</i>	: Bevel Helical PKD 2390 High Efficiency
<i>Hydraulic Motor</i>	: 0,37kW
<i>Hydraulic Tank Capacity</i>	: 8 Liters
<i>Coolant Motor</i>	: 0,12kW
<i>Coolant Tank Capacity</i>	: 25 liters
<i>Conveyor Motor</i>	: 0,12kW
<i>Blade Speed</i>	: 25-90 m/min
<i>Blade Dimensions</i>	: 4.300 x 34 x 1, 1 mm
<i>Machine Weight</i>	: 995kg
<i>Machine Dimensions</i>	: 1.150 x 2.500 x 1.300 mm
<i>Table Height</i>	: 730 mm

STANDARD ACCESSORIES

Digital Control Panel

Only control panel without buttons
Error page
Alarm list
Easy language selection
Easy denomination selection



Inverter

Provides to adjust blade speed up to workpiece diameter, thickness and hardness.



Moveable Control Panel



Hydraulic Vise

Pressure, clamping period and clamping time can be adjusted.

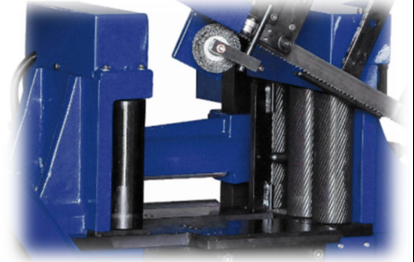

Fast Down Speed Approach



Hydromechanical Blade Tensioning and Manometer

Blade does not relax
and curve cutting gets prevented.

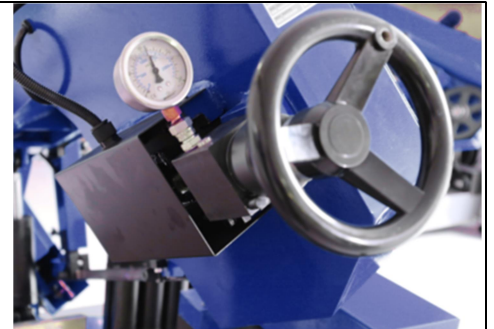

Bedding with 2 Bearings and Carbide Plate



Swarf Brush

Removes swarfs to keep clean the
wheels and blade.

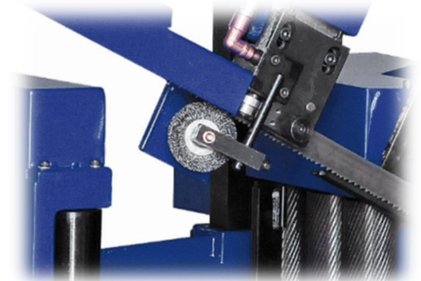

1,4 m Roller Table



Helical Channeled Feeder Roller

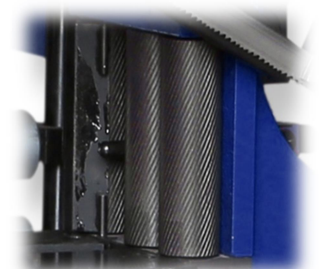

Material Move Support Roller

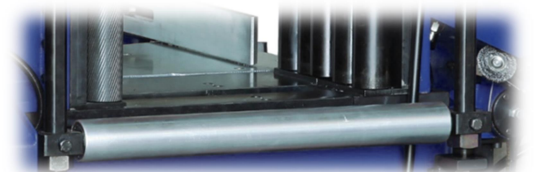

Adjustable Bow Down Speed



Adjustable Vise Pressure and Manometer



Transport Hooks



Levelling Foot Leg



Bow Switch



Tension Switch



Electric Cabinet Switch



Bearing Bedding at Wheels



Moveable Guide Arms

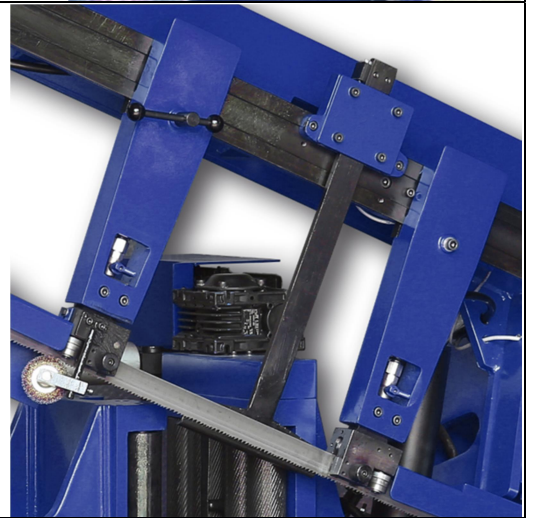

Bevel Helical Gearbox

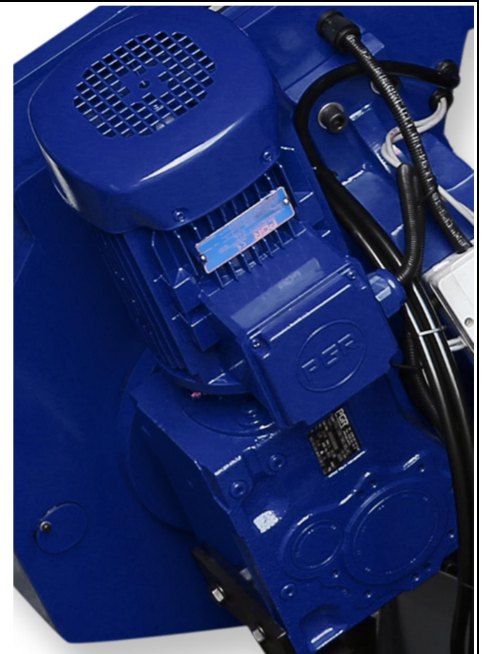

Mechanical Top Clamps



Helical Channeled Feeder Bars

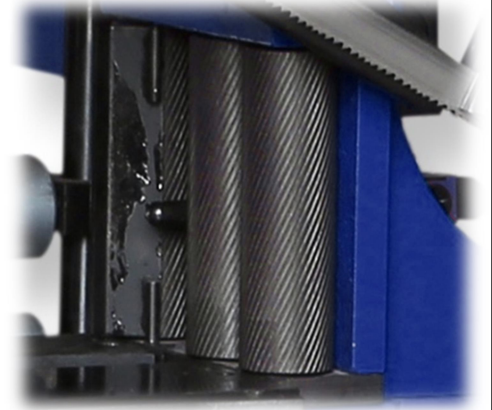

Rope Holes for Moving Machine

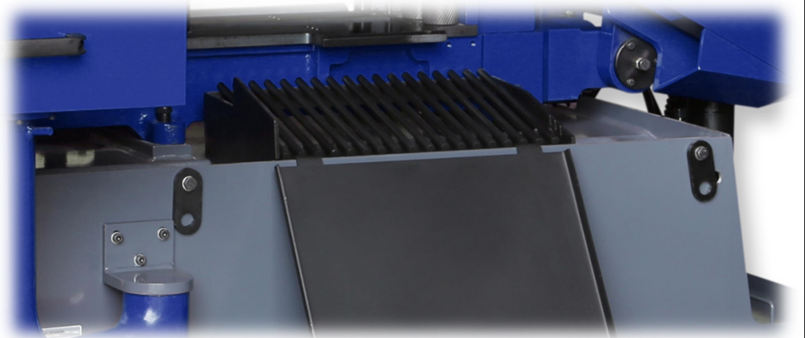

Height Adjustment Switch

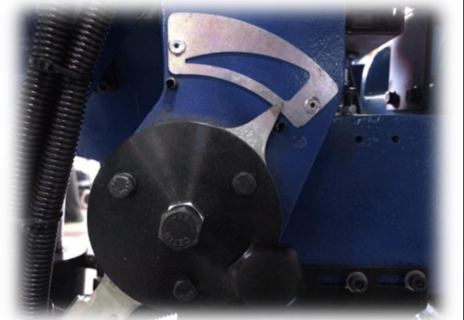

S.A.P (Italy) Brand Coolant Pump

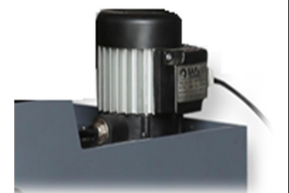

Automatic Stop When;

- The covers are open
- Blade is broken
- Blade tension is low



OPTIONAL ACCESSORIES

Laser Line Indicator



Micro Molecular Coolant System



Swarf Conveyor
Remove swarfs from machine by
Motor driven conveyor.



SAFETY EQUIPMENT

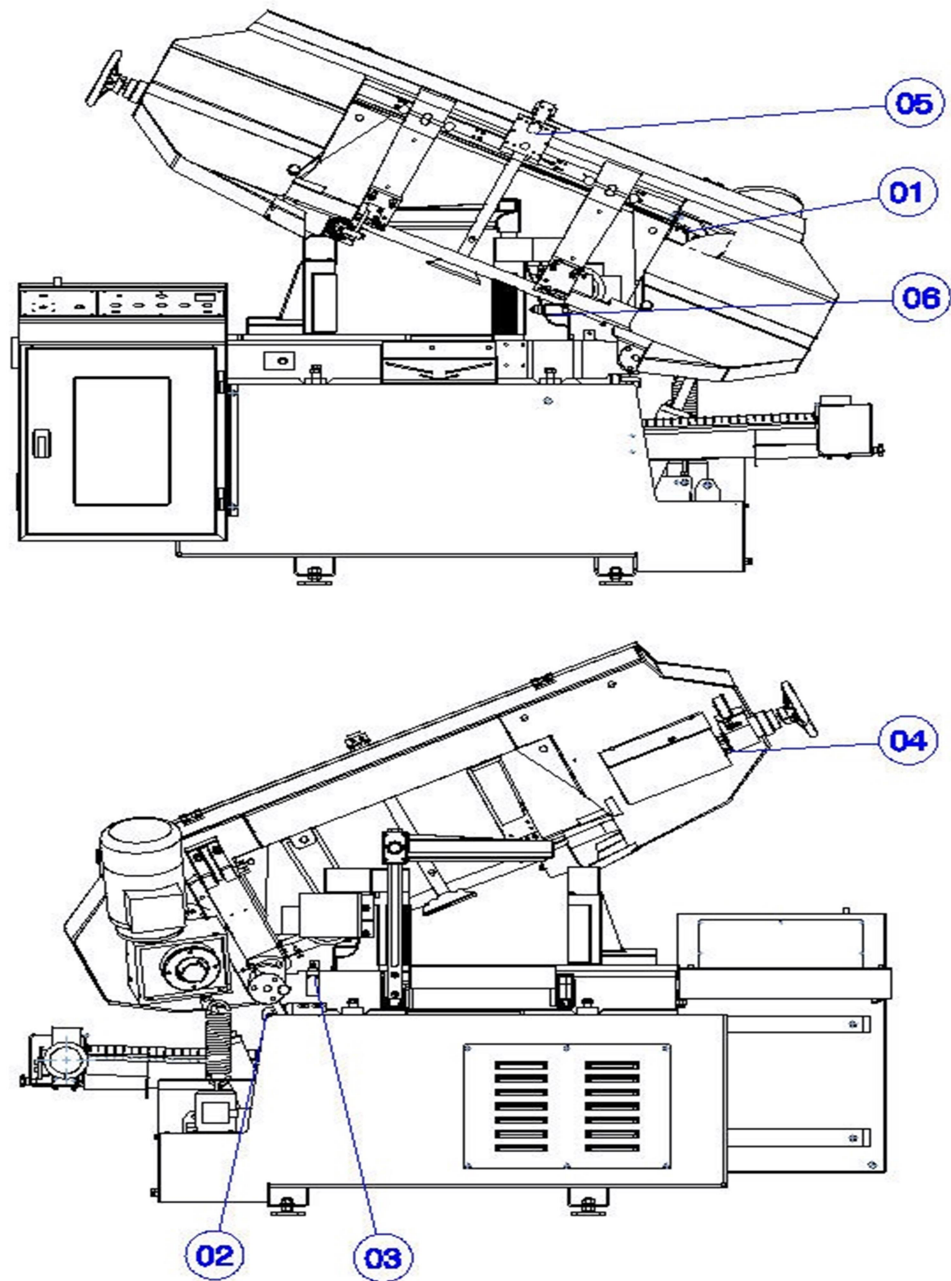

01	Cover Switch	150 01 020
02	Bottom Limit Switch	150 01 254
03	Upper Limit Switch	150 01 022
04	Hydraulic Band Tension Sw.	150 01 050
05	Height Adjustment Switch	150 01 020
06	Vise Switch	150 01 020

TERMS

Delivery (After Receipt of written PO) :

Type of Delivery : **Exwork**

WARRANTY CONDITIONS

The machine is under the warranty of SAPHIR For a period of 2 years for mechanical parts, 1 year for electric and electronic parts from the date of purchase. This warranty is subject to all of the terms and conditions listed below:

1. This warranty is valid only if the **Warranty Registration Form** is filled in and returned to the manufacturer or its authorized dealer within **two months after the** date of purchase.
2. The obligation of the manufacturer under this warranty shall be limited to repairing or replacing components which proves defective and which our examination shall disclose to our satisfaction to be defective.
3. Defects due to improper operation, misuse, neglect, alteration, irregular voltage conditions, inadequate wiring, improper installation (**all electrical and electronic components, all electrical motors etc.**) and due to accidents or any damage caused by transportation, flood, fire, natural disasters, theft are not included in this warranty and are strictly the responsibility of the purchaser.
4. Any part returned to SAPHIR or its authorized dealer under the terms of this warranty shall be on the basis of transportation charges prepaid by the customer and must be accompanied by a record of the machine model code and serial number.
5. This warranty does not apply to the following components; band saw blade, blade pressure pads or brackets and blade guide bearings **because of being consumables**.
6. Manufacturer and authorized dealer cannot be blamed within maximum repair period for the material or moral damage. Apart from that act the period as Warranty Conditions and there will not be done any retroactive requirement.



SAPHIR BANDSAW MACHINES
Hanlı Merkez Mah. Hatip Sok. No:32
Arifiye/Sakarya/TURKEY
Phone: +90 264 276 59 16
Fax: +90 264 276 59 19
www.saphirbandsaw.com
sales@saphirbandsaw.com